

MQ-2 Smoke Sensor Module



Description:

The MQ2 sensor is one of the most widely used in the MQ sensor series. It is a MOS (Metal Oxide Semiconductor) sensor. Metal oxide sensors are also known as Chemiresistors because sensing is based on the change in resistance of the sensing material when exposed to gasses. The MQ2 gas sensor operates on 5V DC and consumes approximately 800mW. It can detect LPG, Smoke, Alcohol, Propane, Hydrogen, Methane and Carbon Monoxide concentrations ranging from 200 to 10000 ppm.



It also protects the sensor and filters out suspended particles, allowing only gaseous elements to pass through the chamber. A copper-plated clamping ring secures the mesh to the rest of the body.

How Does a Gas Sensor Work?

When a SnO₂ semiconductor layer is heated to a high temperature, oxygen is adsorbed on the surface. When the air is clean, electrons from the conduction band of tin dioxide are attracted to oxygen molecules. This creates an electron depletion layer just beneath the surface of the SnO₂ particles, forming a potential barrier. As a result, the SnO₂ film becomes highly resistive and prevents electric current flow.

In the presence of reducing gasses, however, the surface density of adsorbed oxygen decreases as it reacts with the reducing gasses, lowering the potential barrier. As a result, electrons are released into the tin dioxide, allowing current to freely flow through the sensor.

Hardware Overview

The MQ2 gas sensor is simple to use and has two different outputs. It not only provides a binary indication of the presence of combustible gasses, but also an analog representation of their concentration in air.

The sensor's analog output voltage (at the A0 pin) varies in proportion to the concentration of smoke/gas. The higher the concentration, the higher the output voltage; the lower the concentration, the lower the output voltage. The animation below shows the relationship between gas concentration and output voltage.

This analog signal is digitized by an LM393 High Precision Comparator and made available at the Digital Output (D0) pin.

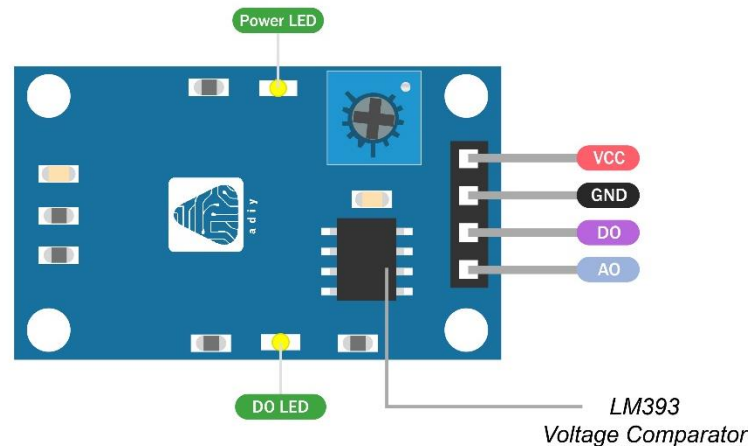

The module includes a potentiometer for adjusting the sensitivity of the digital output (D0). You can use it to set a threshold so that when the gas concentration exceeds the threshold value, the module outputs LOW otherwise HIGH.

In addition, the module has two LEDs. The Power LED illuminates when the module is turned on, and the Status LED illuminates when the gas concentration exceeds the threshold value.

Specifications:

1. Operating Voltage :- 5V
2. Load Resistance :- 20K Ω
3. Heater Resistance :- 33 $\Omega \pm 5\%$
4. Heating consumption :- <800mw
5. Sensing Resistance :- 10 K Ω - 60 K Ω
6. Concentration Scope :- 200 – 10000 ppm
7. Preheat Time :- Over 24 Hour

Pin Configuration:

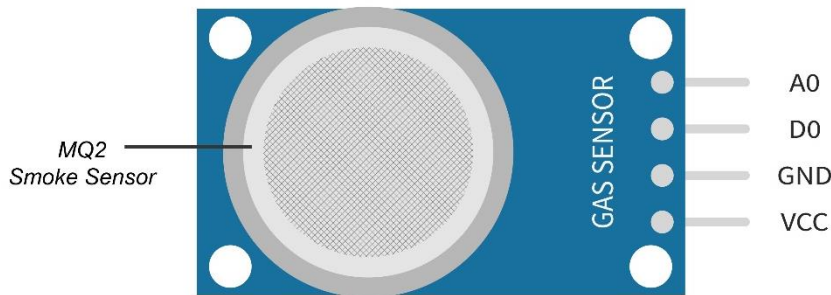

VCC: Supplies power to the module. Connect it to the 5V output of your Arduino.

GND: Is the ground pin.

DO: Indicates the presence of combustible gasses. D0 becomes LOW when the gas concentration exceeds the threshold value (as set by the potentiometer), and HIGH otherwise.

AO: Produces an analog output voltage proportional to gas concentration, so a higher concentration results in a higher voltage and a lower concentration results in a lower voltage.

Application:

- Gas leakage detection
- Toys
- IoT Applications
- Smart Detections

